

Ready Track™

OT fixed

PT fixed

RTC fixed



Owner's Manual

- Use and features
- Troubleshooting
- Maintenance
- Warranty
- Specifications

Instructions for use

The instructions in this manual are limited to the use of the lift itself. For instructions on the attachment, use, and care of slings; please refer to the appropriate sling owner's manual.

Before initial use

To protect the lift during shipping, the batteries power supply has been disengaged. Engage the batteries by re-setting the red EMERGENCY STOP pull cord switch. initial use, the lift should be fully charged in accordance with the charging instructions.

Turning the power on

To start the lift, press the white POWER button on the hand control and hold down for 2 seconds to allow the electrical system power up. The red and green LEDs on the lift will illuminate, while the equipment performs a check of all electrical functions. At the end of the 2 seconds only the green LED remains lit, indicating that the electrical system is functioning properly.

Failure to power up

Due to operator error

- If the POWER button is released too quickly, the red and green LEDs stay on and an alarm sounds. Use the POWER button to turn the system off and start over.
- If a function key is pressed before the system has powered up (with or without the red LED flashing) use the POWER button to turn the system off and start over.

Due to system failure

- If an electrical fault is detected during power-up, the red LED starts flashing. Use the POWER button to turn the system off and have the lift serviced.

Hand Control*

1. Power on/off
2. Return to charge
3. Up
4. Down
5. Lift traverse left
6. Lift traverse right

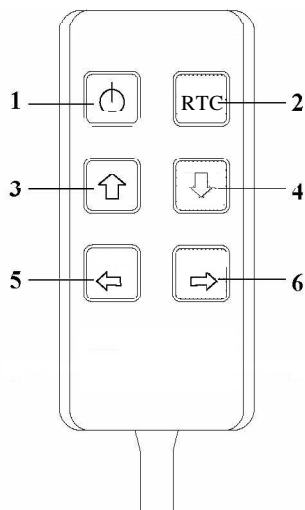

*Return to charge
Hand control Shown

Carrybar

The carrybar comes in a 3-point (475lb capacity) or 5-point (650 or 1000lb capacity) configuration. The lift strap is attached to a dowel housed inside the hanger pin. Detaching and re-attaching carrybars may be done on site by qualified personnel.

Turning the power off

The green LED on the lift indicates that the power is on. To turn the power off, press the white POWER button on the hand control. For battery conservation, a lift that has been left on will turn itself off after 10 minutes of idle time.

Operating the lift

Press the appropriate function key on the hand control: UP, DOWN and, where applicable, LIFT (power) TRAVERSE.

No unattended movement

Function keys must be kept pressed by the operator for ongoing operation. Lifts that are equipped with return to charge circuitry will return to the charger when the RTC button is pressed.

No simultaneous activation

Pressing more than one key at once results in a single function being activated in priority sequence:

1. On-off
2. Down
3. Up
4. Lift traverse

Direction of motorized horizontal travel (where applicable)

The colors of the LIFT TRAVERSING buttons on the hand control correspond to the colors of the double arrow on the lift. Pressing the white (or blue) button traverses the lift in the direction of the white (or blue) arrow.

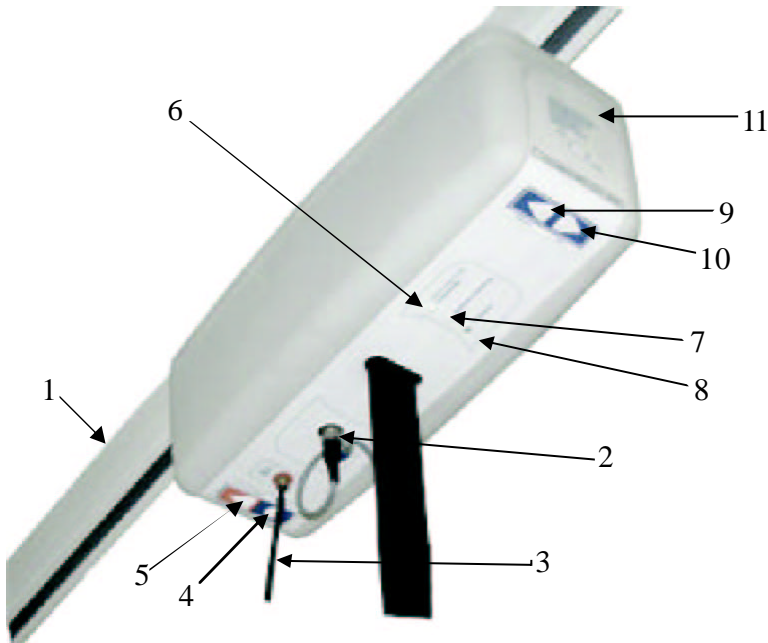

Lift and track

1. Straight Track
2. Hand control attachment
3. Emergency stop pull cord
4. Power on/off
5. Emergency down
6. Low battery and diagnostics (red LED)
7. Charger docking light (orange LED)
8. Power (green LED)
9. Down
10. Up
11. Manual lifting and lowering

Not visible

12. Circuit breaker (on top)
13. Actuation counter (on top)

Operator traversing (OT)

The OT lift is traversed manually: the operator takes hold of the carrybar and pulls the lift along. Alternatively, when there is a patient in the lift, the operator may prefer to traverse the lift by placing a hand on the user's back or taking hold of a sling strap. The PT and RTC models are power traversed, but may be operator traversed as well if so desired without any damage to the lift.

The hand control and emergency pull cord is **NOT** a tether

- Using the electrical hand control as a tether will damage the electrical cord.

Power Traversing (PT)

The power traverse lift can be traversed in either direction as indicated by white and blue arrows on the lift. Choose the color arrow direction you wish to go and press the corresponding button on the hand control.

Return to Charge (RTC)

The return to charge feature activates the lift unit to raise the carry bar, drive itself to dock in the charger, and lower the carry bar for access. The feature is cut off when any weight is detected in the sling.

Docked Lift

As a safety precaution, the carry bar cannot be raised when the lift is in the charger. It can be lowered for access.

Back-up operating controls

Button back-up

The red DOWN button on the hand control is an alternate down to protect against failure of the blue DOWN button.

On-unit hand control back-up

The blue on-unit membrane switches duplicate the POWER and UP/DOWN functions on the hand control to protect against failure of a hand control button or hand control connection.

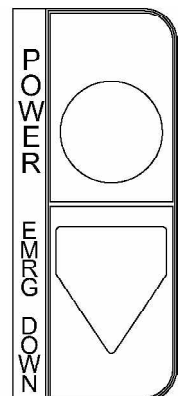
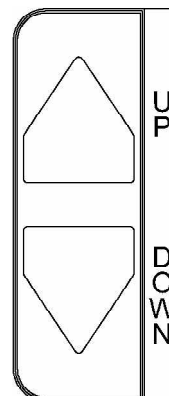

Emergency controls

To guard against unintended use, there are no emergency controls on the hand control. All such controls are located on the lift.

Emergency Down

- The on-unit red DOWN membrane switch is an EMERGENCY DOWN, which functions independently of the circuit board's microprocessor. An alarm sounds and the steady red LED on the lift illuminates when EMERGENCY DOWN is activated.
- The alarm and red LED will stay on until the power is turned off. In the event of unnecessary activation of the EMERGENCY DOWN, the lift may be turned back on and continue to be used. Otherwise, a lift that has been lowered in emergency mode should be taken for service.
- The speed of descent in emergency mode is 4 inches per second compared with an average 2.5 inches in normal use.

Emergency stop

The on-unit red EMERGENCY STOP pull cord switch instantly cuts power to the lift by isolating the batteries. In the event of unnecessary activation, the STOP switch may be reset for continued operation.

Circuit breaker

Sustained electrical overload will trip the RE-SETTABLE CIRCUIT BREAKER on the top cover of the lift. Push the button to reset.

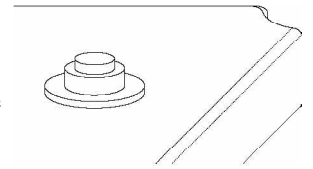

Manual raising and lowering

In the event of overall electrical failure, remove the access plug on the side of the lift, insert a socket wrench, and RAISE or LOWER MANUALLY. Turning clockwise lowers the lift. To raise, turn counter-clockwise. Use of a power tool (a 5/16" hex socket is required) enables the lift to operate at normal speed.

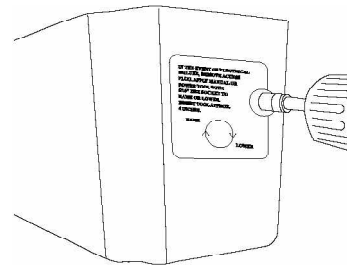

Safety of hand controls in wet and humid environments

Hand controls are safe in wet and humid environments. The electric hand controls have an ingress protection (IP) rating of 67 and will continue to operate safely during and after full immersion.

Low battery signals

When the batteries require re-charging, the steady red LED on the light lights up. If the lift continues to be operated with the batteries are low, an alarm will sound. There will always be enough power left to lower a user, should the low battery signals come on during a lift-and-transfer in progress. However, ongoing operation of the lift will eventually discharge the batteries to the point where the battery life and performance will be affected. If the batteries are kept fully charged on a daily basis, the low battery signals may never come on in normal use, except when the batteries are due for replacement

Daily charging of batteries

Batteries should be fully charged every 24 hours. Depending on the initial charge, re-charging may take up to three hours. The charger has built-in protection against overcharging, making it safe to leave the lift connected to the charger indefinitely. Provided the batteries are kept properly charged and are used in a non-corrosive environment, the life expectancy of batteries may be several years.

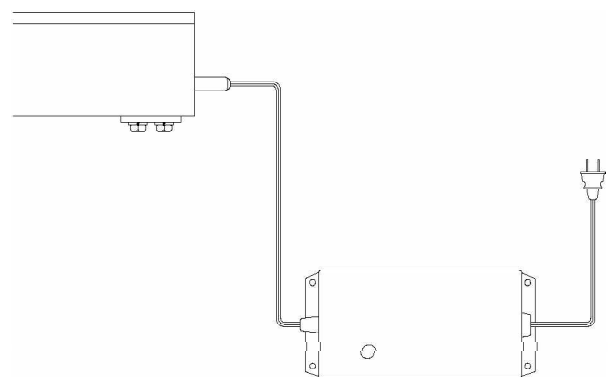

Charging and charging signals

To charge the batteries, drive or manually traverse the lift into the charger docking station at the charger end of the track. The orange LED on the lift indicates that the lift is properly docked. The LED stays orange for as long as the lift is docked. The charger LED will provide the status of the charging process.

Charger LED green-while the lift is not on charge (the middle LED on the lift is off)

A green charger light, while the lift is not on charge, indicated that the charger is receiving power from the main. No light means that the charger is not getting power.

Charger LED orange-while the lift is on charge (the orange LED on the lift is on)

A orange charger light, while the lift is on charge, means that the batteries are being charged.

Charger LED green-while the lift is on charge (the orange LED on the lift is on)

A green charger light, while the lift is on charge, means that the batteries are fully charged

AC protection

While the lift is on charge, the up function of the lift is automatically disabled to protect against potential AC exposure from charger insulation failure. The power-traversing mode, where applicable, continues to be operational while the lift is on charge.

Overheat, overload and electrical fault signals

A flashing red LED on the lift indicates overheat, overload or electrical fault conditions. The first two are caused by operating conditions, the third one indicates detection of an electrical fault during power-up.

2 flashes followed by pause	overheat condition
continuous flashing	overload condition
3-7 flashes followed by pause	various electrical fault mode

If someone is in the lift when the red LED starts flashing, use either of the DOWN buttons on the hand control to lower the person. If the DOWN buttons do not operate, use the appropriate emergency control on lift.

Trouble shooting

If the lift does not respond to any commands from the hand control

Check to see if the emergency stop has been activated. Pull the cord and try again. If this does not resolve the problem, try the override controls on the lift (be sure to reset the emergency stop again). If the lift now works, the hand control needs to be replaced. If not, return it to the charger and check that the LED indicates that the unit is taking a charge. If it does not work after a three hour recharge, call for service.

If the lift does not rise - possible cause and resolution

Lift will not rise when docked in charger. Be sure lift is out of charger.

Lift strap may be safely angled up to 45 degrees in either of the traversing directions, for example at the end of a section of track. Lifting at an angle of more than 10 degrees perpendicular to the direction of travel may cause the strap to fold and could trip the upper limit switch (also known as the "tape thickness switch"). The lift will stop, should this happen. To correct the situation, lower the lift to untwist the strap and resume lifting within the 10-degree limit. No service call is required, if the lift now operates correctly. If the lift does not function, call for service.

If the lift continues to perform a function even though the function key is no longer being pressed - possible cause and resolution

The switch may be stuck. Turn off the power to discontinue the function. Then press EMERGENCY LOWER, the only function on the lift, which will operate without first powering up the electrical system. Have the lift serviced for switch or hand control replacement.

If the carrybar does not lower - likely cause and resolution

If a carrybar fails to lower, the lower limit switch (also known as the "slack tape switch") has likely gone out of alignment. It is safe to continue with the lift-and-transfer in progress by placing a hand on the carrybar and applying slight downward pressure. Following completion of the lift-and-transfer, have the lift serviced to correct the misalignment.

Resetting the unit

A potential source of a sporadic malfunction is a problem with the control board. The control board can be reset by pressing the unit emergency down switch for one second and let it off. Wait two seconds and turn the unit power switch off. Wait two more seconds and turn the unit power switch back on. The green power LED should now be on.

Cleaning

The lift cover, including labels, membrane and other switches, hand control, and carry bar can be wiped down with disinfecting wipes.

Warranty

Warranties are limited to manufacturer's defects and exclude the effects of normal wear and tear, unintended use, operator abuse, concussive impacts and external factors including sustained exposure to heat lamps or radiant heat and exposure to liquids, vapors, chlorine and other corrosive substances. Barton Medical's liability under the warranties is limited to replacing defective parts and does not extend to consequential repairs or modifications to the equipment.

Drive train and gearbox

The drive train and gearbox have a 3-year warranty.

Batteries

Batteries have a warranty of 90 days

All other components

All other components, including hand controls, Circuitry, wiring, switches, plugs, covers, trolleys, And straps have a one year warranty.

Maintenance

The following items need to be performed at the recommended intervals.

1. Procedure

1.1. Recommended Tool List

- 1.1.1. Socket Set 7/16" and 9/16" with extension
- 1.1.2. Adjustable Torque Wrench – Adjustable up to 40ft/lbs
- 1.1.3. Screw Driver Set (W/ Multiple Bits)
- 1.1.4. Multimeter (0-50VDC)
- 1.1.5. Step Stool or ladder
- 1.1.6. Gloves
- 1.1.7. Needle nosed pliers
- 1.1.8. Allen wrench set
- 1.1.9. Flashlight

1.2. Check list prior to **EACH USAGE**

- 1.2.1. Check lift strap, make sure there is no fraying
- 1.2.2. Check all Strap stitching. Make sure all slings show no unusual signs of wear and tear
- 1.2.3. Check that all functions of the hand control are working properly
- 1.2.4. Make sure that there is no visual damage to lift or carry bar
- 1.2.5. Make sure the lift is not making any unusual sounds when in use
- 1.2.6. Be sure that all end stops are installed and secured at every track end

1.3. Check list for **QUARTERLY MAINTENANCE TO BE PERFORMED BY TRAINED PROFESSIONAL ONLY**

- 1.3.1. Complete the entire visual inspection in Section 1-2
- 1.3.2. Check that all lifts are getting charge from charger
- 1.3.3. Check that all brackets holding track (FIGURE 1) are secured and do not move



Bracket holding track and bolt

FIGURE 1

- 1.3.4. Check that all bracket bolts (FIGURE 1) are tightened to 5 ft/lb
- 1.3.5. Check that all endstops bolts (FIGURE 2) are tightened to 25 ft/lb (two bolts per end stop)



Endstop bolts

FIGURE 2

- 1.3.6. The lift should move freely and traverse entire length of track system
- 1.3.7. Call Barton Medical if any problems occur or if parts are needed to be replaced

1.4. Check list for **ANNUAL MAINTENANCE – TO BE PERFORMED BY TRAINED PROFESSIONAL ONLY**

- 1.4.1. Complete all steps noted above in section 1-2 and 1-3.
- 1.4.2. Remove track lift from track and place it on a clean and flat surface.
- 1.4.3. Lower carry bar by pressing down button on hand controller or down button on lift. If there is no weight on the strap, a sensor inside the lift will not allow it to lower. Pulling on the strap will disengage the sensor and allow the strap to be extended far enough to allow the cover to be removed. Remove cover of the ceiling lift by removing all four nylon screws. As you separate the cover from the lift chassis, you will need to unplug the connectors to the cover mounted electronics.
- 1.4.4. All O-rings (4) should be inspected and replaced if there are any signs of brittleness or stretchiness. It is recommended to change O-rings every 12 months regardless of their condition. O-rings are subject to ambient air condition, temperature, frequency of use, etc. ; all of which may affect life expectancy. Indicators of O-ring issues are:
 - 1.4.4.1. If slackening of belt does not immediately engage lower limit switch
 - 1.4.4.2. If fully wound belt does not immediately engage upper limit switch. (Refer FIGURE 4)
 - 1.4.4.3. Use clean gloves when handling new o-rings to avoid premature failure.

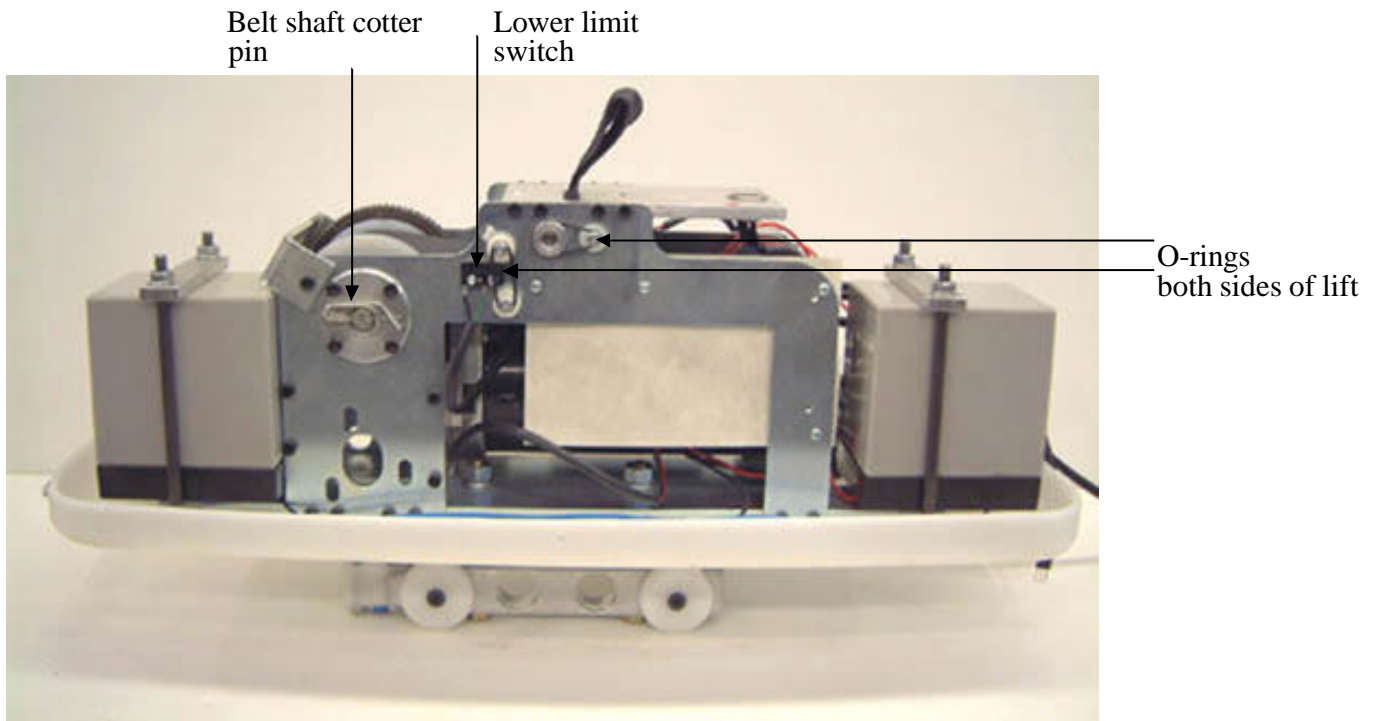

FIGURE 3

- 1.5. Check the function of the Lower Limit Switch (Refer to FIGURE 3) by using the down button on the hand control to unwind the belt.
 - 1.5.1. **On FIXED LIFTS:** as the belt is unwinding under weight of the CARRY BAR, grab the CARRY BAR with your free hand allowing the belt to slacken. The strap should cease to unwind. If the belt continues to unwind, check the O-rings on the Lower Limit Switch and replace if necessary. Alternately, check to ensure the roller (the O-ring is attached to this roller) moves freely in the slot on the side plate. If necessary, clean / remove any debris in this area.
 - 1.5.2. **On PORTABLE LIFTS:** as the belt is unwinding under weight of the LIFT, grab the LIFT with your free hand allowing the belt to slacken. The strap should cease to unwind. If the belt continues to unwind, check the O-rings on the Lower Limit Switch and replace if necessary. Alternately, check to ensure the roller (the O-ring is attached to this roller) moves freely in the slot on the side plate. If necessary, clean / remove any debris in this area.

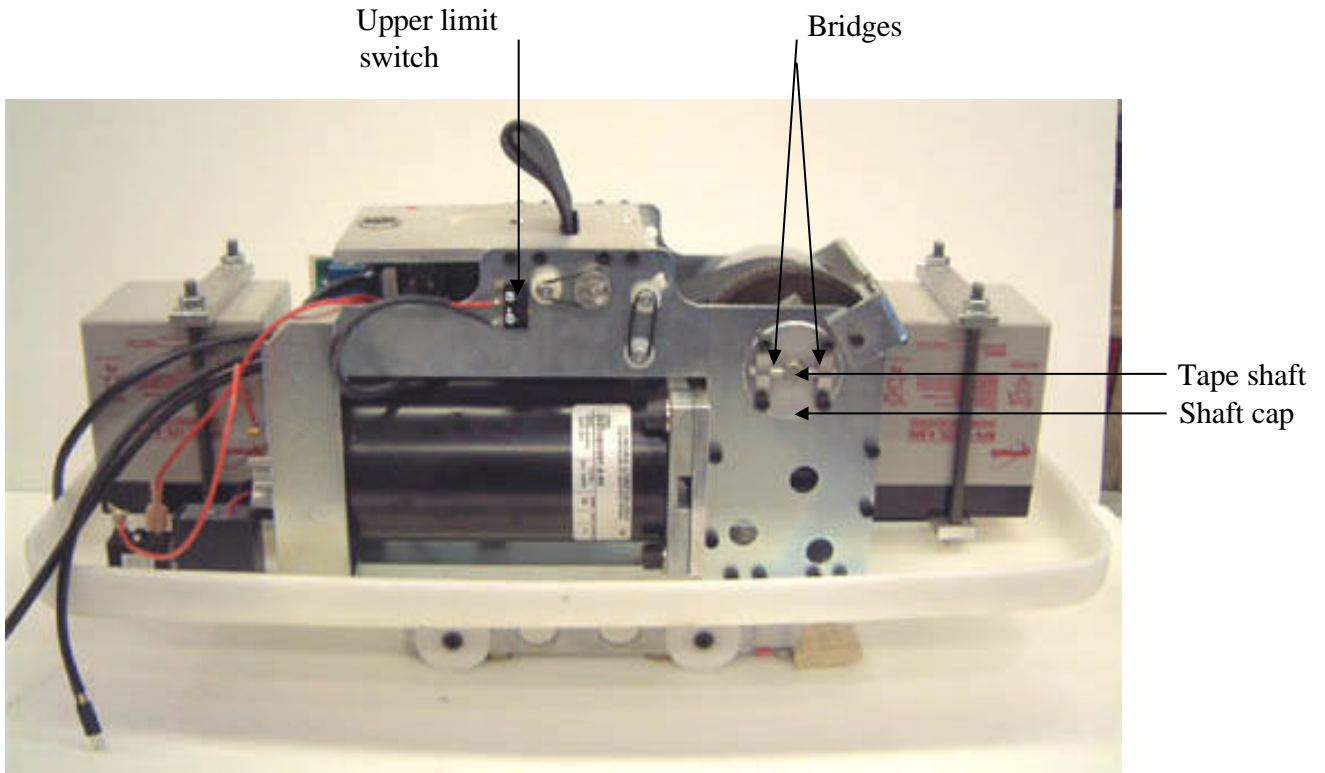

FIGURE 4

- 1.6. Using the handset, check the function of the Upper Limit Switch (FIGURE 4) by winding in the belt fully, thereby activating the Upper Limit Switch. If the switch does not shut down the unit, change both O-rings and repeat this procedure. In the event the switch still does not activate, the metal arm of the switch can be adjusted slightly in order to make better contact with the roller. To adjust: bend the metal arm out slightly using a pair of needle-nose pliers. (Refer FIGURE 4)
- 1.7. Engage the Emergency Lowering on the lift unit (FIGURE 5.) The belt should unwind and a high-pitched sound should be heard within the Lift casing. If there is no sound, there is likely an issue with the PC Control Board. If this is the case contact Barton Medical.



FIGURE 5

- 1.8. Check that all other buttons and switches on the Lift and the handset function properly.
- 1.9. Inspect the shackle at the top of the Carry Bar to ensure the split pin is still in place. If not, insert a 3/32" x 1" split pin in predrilled hole (FIGURE 6) on shackle.

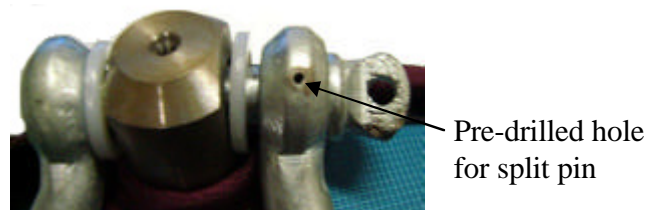

FIGURE 6

- 1.10. Using the Up and Down buttons, on the handset, move the Carry Bar in both directions and check for smooth descent & ascent of belt. If vibration of lift is deemed excessive then contact Barton Medical.

- 1.11. Examine the strap for any fraying or broken stitching. In the event of either being present, change the belt using the following procedure:
 - 1.11.1. Using the handset, unwind the belt to its full extent.
 - 1.11.2. Open the Lift Cover by removing the 4 nylon screws. The Cover can now be moved away from the base so as to access the inside of the Lift.
 - 1.11.3. Remove the wrap-around cotter pin from the belt shaft. (Refer FIGURE 3)
 - 1.11.4. Remove the two bridges from the Shaft Cap. (Refer FIGURE 4)
 - 1.11.5. Pull the tape shaft out only until the belt drops from the unit (the shaft should remain partially in the tape reel).
Be careful to not allow the Shaft Caps to come out of position. (Refer FIGURE 4)
 - 1.11.6. To install new belt reverse the above procedure making sure to push the shaft through the loop in the new belt.
- 1.12. Inspect all hardware fasteners on unit to ensure they are secured tightly. Hand tightens if required.
- 1.13. Visually inspect for excessive wear around the motor and gear parts. Should excessive wear be evidenced contact the Barton Medical at 1-800-387-7103.
- 1.14. Reinstall the cover.

Track Lift Motor Specifications

Model	Portable	Fixed, Standard Duty			Fixed, Bariatric Duty			
	RT-200	RT-400	RT-410	RT-415	RT-600	RT-610	RT-615	RT-1015
Traverse Method	manual		power/motorized		manual	power/motorized		
Return-to-Charge feature	no			yes	no		yes	
Capacity	450 lbs (205 kg)	475 lbs (216 kg)			650 lbs (295 kg)		1000 lbs (454 kg)	
Size	19.2"x7.1"x9" (48.8x18x22.9cm)	20"x7.6"x9" (50.8 cm x 19.3 cm x 22.9 cm)						
Overall Weight	17 lbs (7.7 kg)	24 lbs (10.9 kg)	26 lbs (11.8 kg)	29 lbs (13.2 kg)	31 lbs (14.1 kg)	36 lbs (16.4 kg)		
Lifting Belt	2" (5.1cm) wide "seatbelt" webbing 8' (2.4m) spoolable length							
Allowable Strap Angles	Angling strap: up to 45 degrees in traversing directions, up to 10 degrees perpendicularly							
Up/Down Speed	Up no load 3.0 in/s (7.6cm/s), Down no load 2.0 in/s (5.1cm/s)				Up no load 2.2 in/s (5.6cm/s), Down no load 1.5 in/s (3.8cm/s)			
Power Traverse Speed	n/a	n/a	10 in/s (25.4 cm/s)	n/a	10 in/s (25.4 cm/s)			
Cover and Charger wallbox	ABS/Plastic	Polyethylene/Plastic						
Drive Train	All-metal gearing							
Braking System	Limiting Switch UP/DOWN, Locking Cam preventer (emergency situations)							
Signals	Power-on, Connected-to-charger, Low battery, Emergency down, Overload, Overheat, Start-up electrical fault modes							
Batteries	2 x 12VDC 2.3 Amp hr	2 x 12VDC, 4.0 Amp Hour high capacity, no memory, sealed valve regulated lead-acid (VRLA)						
Charger	Smart charger Input 90-264 VAC 1.0 Amp max Output 24VDC 2.0 Amp max							
Charging Time	from 2.5 hours	from 3 hours						
Lift cycles per Charge	approx. 40 @ 172 lbs (78.2 kg) load	Approx. 150 @ 172 lbs (78.2 kg) load						
Controls	Hand-held electric membrane switch control IP 67, membrane switches on console ("up/down", "power/emergency down" only) Pneumatic hand- control available as option							
Signals/Alerts	Power-on, Connected-to-charger, Low battery, Emergency down, Overload, Overheat, Start-up electrical fault modes							
Safety Features	self-checking circuitry, upper and lower limit switches, soft start/stop, no unattended movement, auto shut-off after ten minutes, auto up disabled while on charge, thermal and current limit protection, alternate down, independent emergency down, emergency shut off, re-settable circuit breaker, manual raising and lowering							
Testing/Standards	Compliance: EN10535 Electrical Components UL / CSA certified							

March 2007